

TOIMIL 100

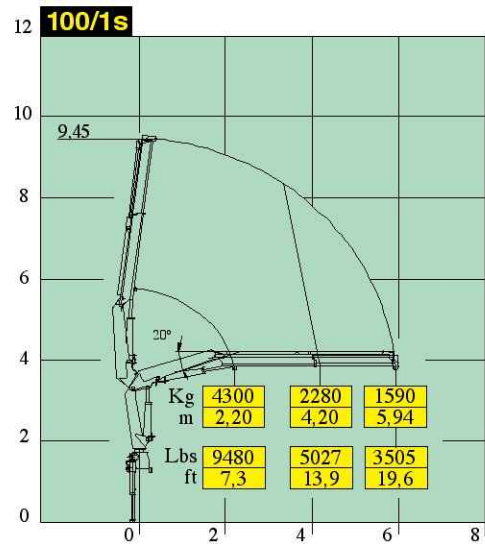

TOIMIL

TOIMIL



DATOS TÉCNICOS - TECHNICAL DATA		100	1S	2S	3S	4S	5S	
Momento de elevación máximo. Max lifting moment.	kNm LbsFt	9,6 Txm						
Alcance hidráulico horizontal. Hydraulic horizontal reach.	m.	6,04	7,84	9,80	11,90	13,85		
Angulo de giro. -Slewing angle.	°	405°						
Velocidad de giro. -Slewing speed.	s (410°)	15°/s						
Inclinación máxima a plena carga. Max slope viable at full capacity.	°	4°						
Presión de trabajo. Working pressure.	Bar	290 Bar						
Caudal máximo al distribuidor. Max oil flow.	L/min	25 L/min.						
Capacidad depósito de aceite. Oil tank capacity.	Litros	60 L						
Peso de la grúa con gatos. Crane weight with stabilizers.	Kg	1330	1410	1510	1600	1670		

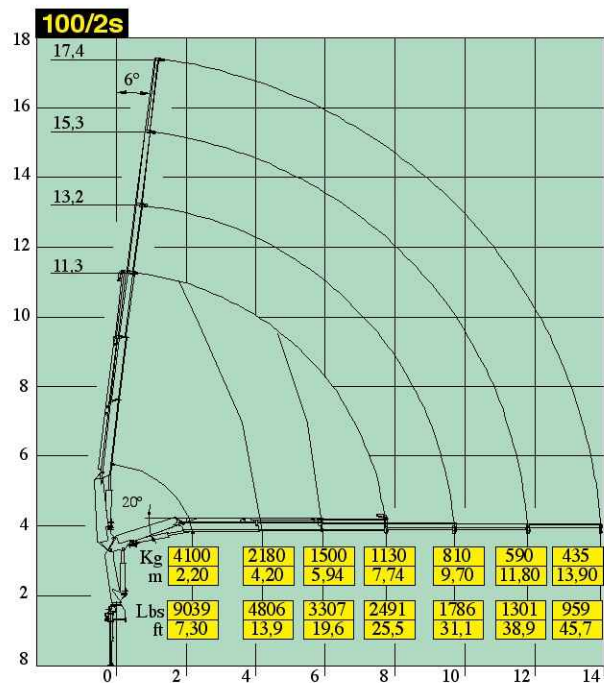

- Limitador de momento
- Mandos cruzados
- Brazos telescópicos hexagonales
- Cilindros extensión independiente
- Gatos estabilizadores fijos
- Estabilizadores extraíbles hidráulicamente
- Valvulas pilotadas
- Deposito de aceite
- Kit de ensamblaje
- Norma del proyecto : EN12999
- Tipo de ensayo a la fatiga: B3
- Sprint Generation System (SGS)
- Electronic Black Box (EBB) only Radio
- Movimiento Suave de Descenso (SDD)



- Load limiting device
- Cross over controls
- Hexagonal Section Extensions
- Independent extension cylinders
- Fixed stabilizer cylinders
- Outriggers with hydraulic extension
- Flanged valves
- Oil tank
- Assembly kit
- Design in accordance with EN12999
- Fatigue test classification: B3
- Sprint Generation System (SGS)
- Electronic Black Box (EBB) only Radio
- Soft Descend Drive (SDD)

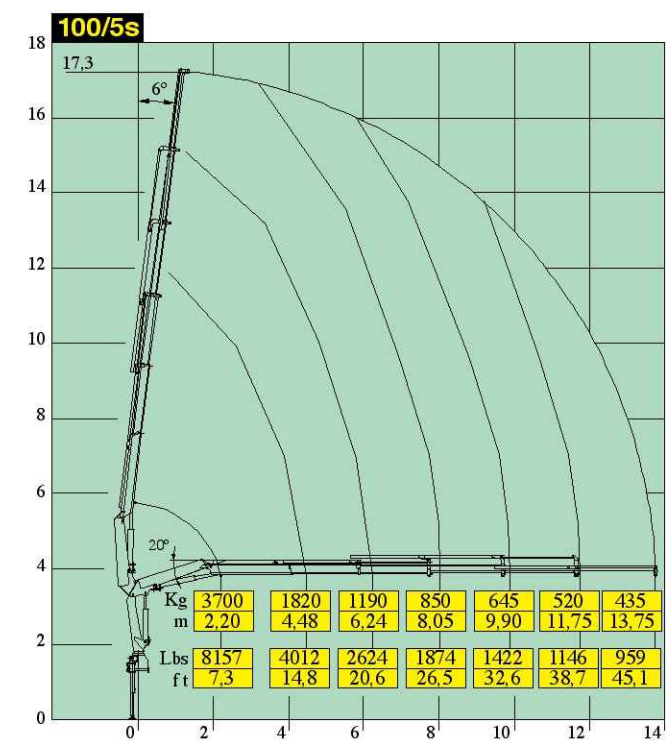
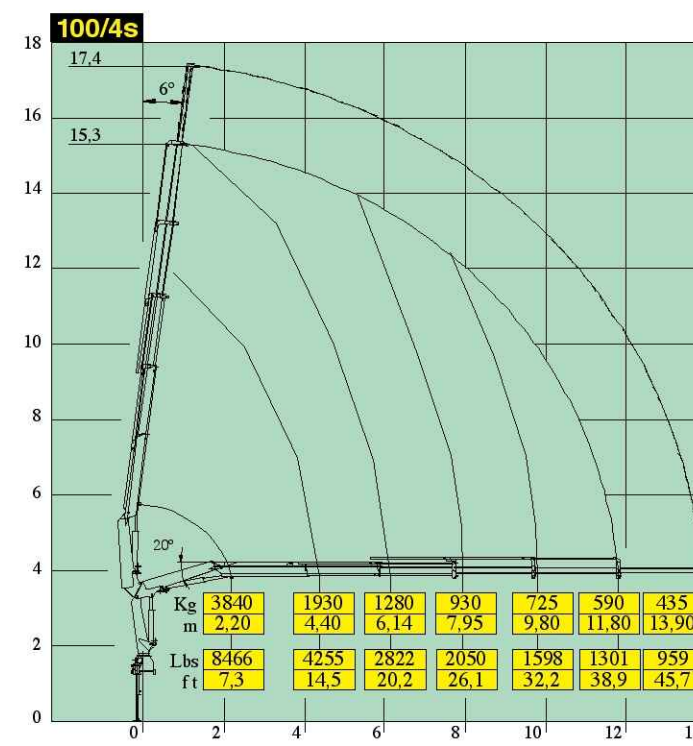
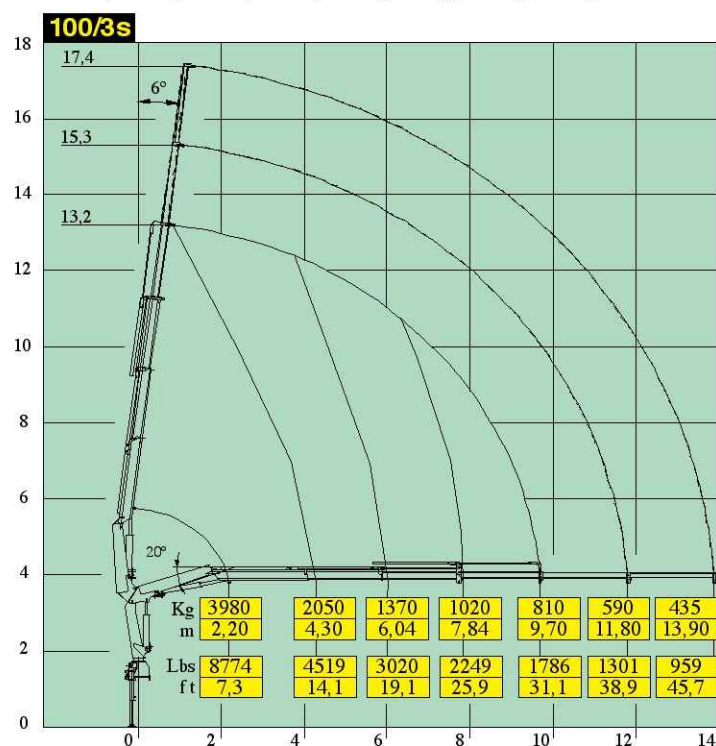

EBB Caja negra electrónica



HNOS. TOIMIL GARCÍA, S.L. ha diseñado esta placa madre de control para asegurar un control eficaz y fiable de la grúa en cada condición de trabajo. El operario puede leer en la pantalla toda la información acerca del estado de la grúa, de los accesorios y del mantenimiento rutinario. Todos los componentes están diseñados de acuerdo con los estándares de la industria automovilística y garantizan la más alta fiabilidad.

+ Seguridad
+ Duración
+ Fiabilidad

HNOS. TOIMIL have designed this control motherboard to assure an effective and reliable control of the crane in every working condition.

The operator can read on the display all the information about the state of the crane, of the accessories and the routine maintenance. All the components are designed according to automotive industry stds. and assure the highest reliability.

+ Safety
+ Longer life
+ Certainty

SDD Movimiento suave de descenso



El sistema SDD está diseñado para reducir las oscilaciones y asegurar un control perfecto de los movimientos.

The SDD system is designed to reduce the oscillations and assure a perfect control of the movements.

+ Control
+ Precisión

+ Control
+ Precision

SGS Sistema extensible regenerativo



El objetivo de este sistema es incrementar la velocidad de las prolongas sin afectar a la seguridad de la grúa.

+ Velocidad

Purpose of SGS system is to increase the extension speed without affecting the crane safety.

+ Speed

Comparativo de velocidad en extensiones Extensions speed comparison					
Modelo*	2S	3S	4S	5S	6S
Standard	20 Sec.	32 Sec.	42 Sec.	51 Sec.	60 Sec.
SGS	10 Sec.	16 Sec.	22 Sec.	29 Sec.	36 Sec.

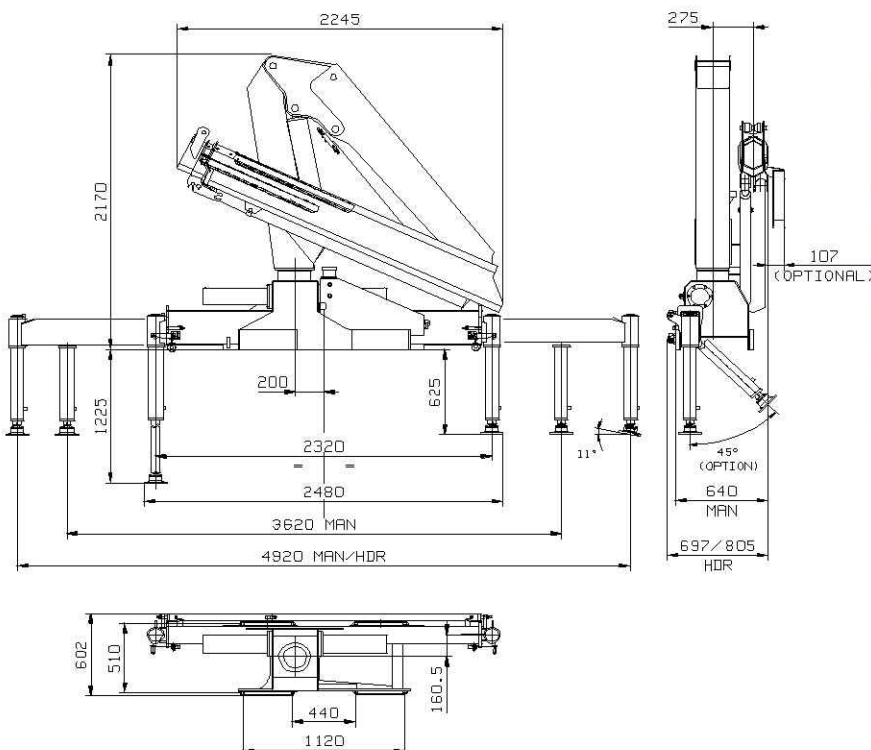

Hnos. TOIMIL GARCÍA, S.L.

Equipos Forestales

GRUAS HIDRAULICAS

Forestales - Industriales - Marinas

Teléfono: + 986 79 40 44 Fax: + 986 79 40 47 Móvil: 609 08 90 06

36512 PRADO - LALIN - PONTEVEDRA (España)

E-mail: toimil@toimilgruas.com

www.toimilgruas.com

Distribuidor:
Distributor: