

# TOIMIL 200



TOIMIL

TOIMIL



Radiocontrol multifunciones (Danfoss)



Radio remote control system with pressure compensated valve block (Danfoss)



## DATOS TÉCNICOS - TECHNICAL DATA

|   |              | 200       | 1S   | 2S    | 3S    | 4S    | 5S    | 6S    | 5S/J2s |
|---|--------------|-----------|------|-------|-------|-------|-------|-------|--------|
| Momento de elevación máximo.<br>Max lifting moment.                     | kNm<br>LbsFt | 20 Txm    |      |       |       |       |       |       |        |
| Alcance hidráulico horizontal.<br>Hydraulic horizontal reach.           | m.           | 6,25      | 8,10 | 10,10 | 12,00 | 14,10 | 16,20 | 19,70 |        |
| Angulo de giro. -Slewing angle.   | °            | 400°      |      |       |       |       |       |       |        |
| Velocidad de giro. -Slewing speed.                                      | s (410°)     | 15°/s     |      |       |       |       |       |       |        |
| Inclinación máxima a plena carga.<br>Max slope viable at full capacity. | °            | 4°        |      |       |       |       |       |       |        |
| Presión de trabajo.<br>Working pressure.                                | Bar          | 295 Bar   |      |       |       |       |       |       |        |
| Caudal máximo al distribuidor.<br>Max oil flow.                         | L/min        | 40 L/min. |      |       |       |       |       |       |        |
| Capacidad depósito de aceite.<br>Oil tank capacity.                     | Litros       | 130 L     |      |       |       |       |       |       |        |
| Peso de la grúa con gatos.<br>Crane weight with stabilizers.            | Kg           | 2280      | 2390 | 2540  | 2680  | 2780  | 2880  | 3120  |        |

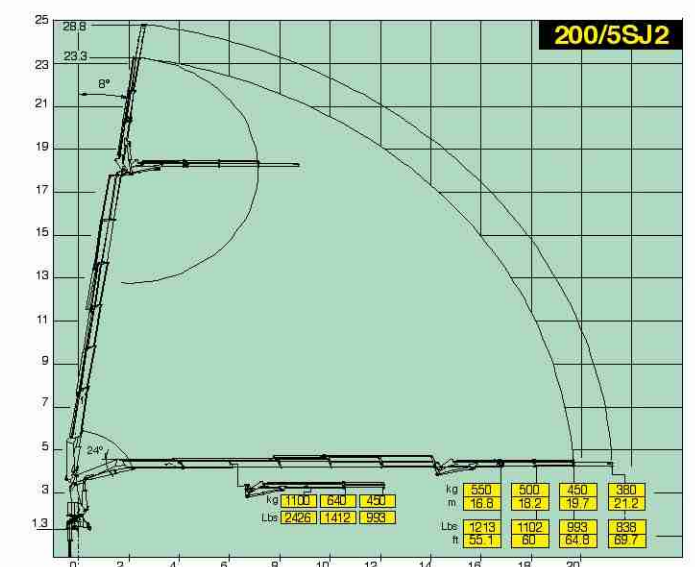
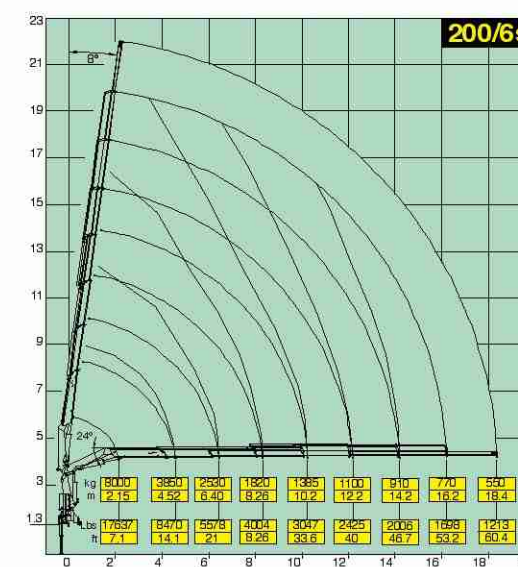
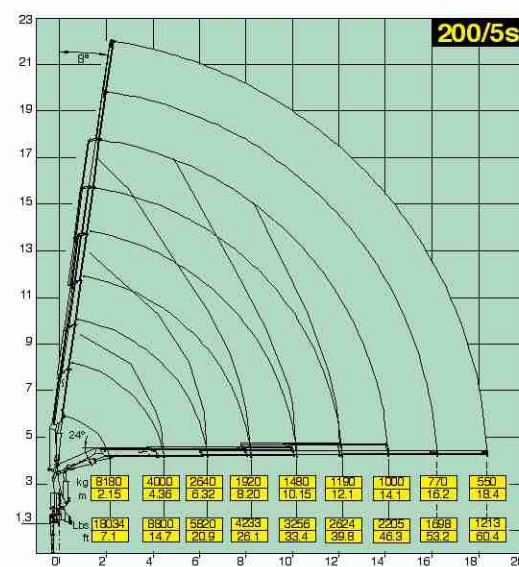
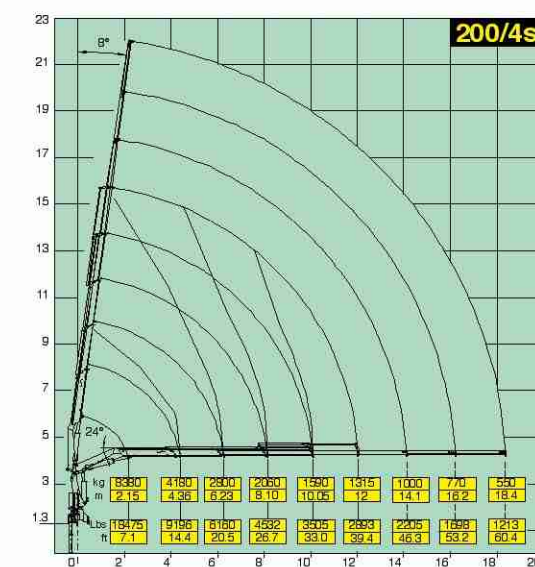
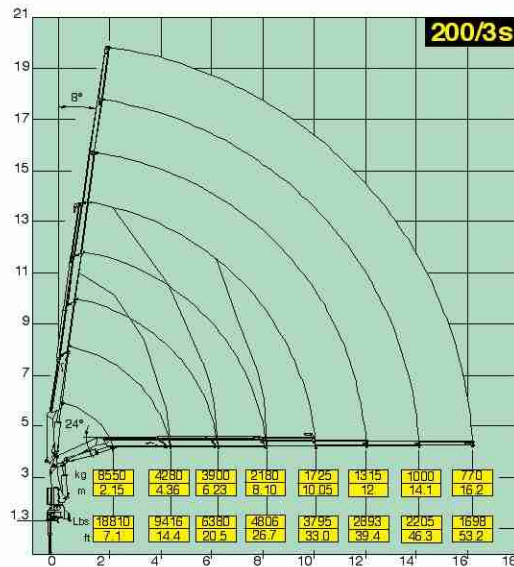
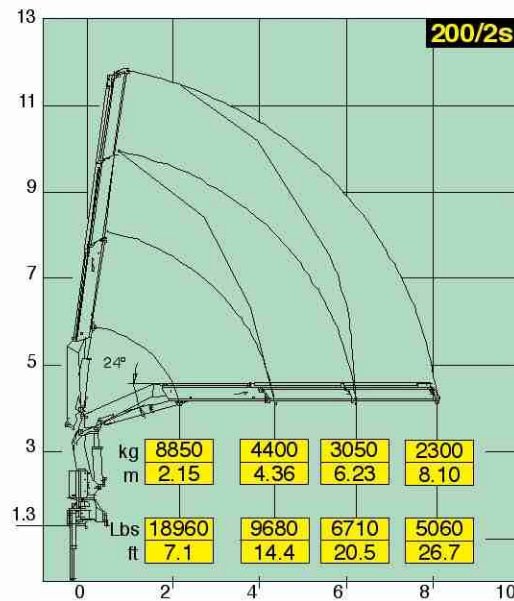
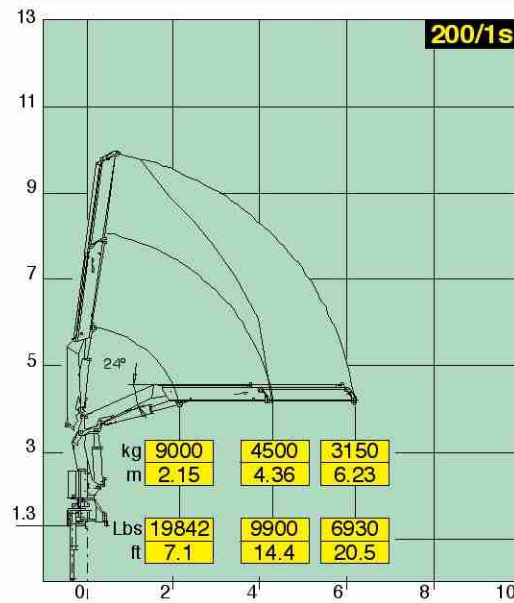

- Limitador de momento
- Mandos cruzados
- Brazos telescópicos hexagonales
- Cilindros extensión independiente
- Gatos estabilizadores fijos
- Estabilizadores extraíbles hidráulicamente
- Válvulas pilotadas
- Depósito de aceite
- Kit de ensamblaje
- Norma del proyecto : EN12999
- Tipo de ensayo a la fatiga: B3
- Sprint Generation System (SGS)
- Electronic Black Box (EBB) only Radio
- Movimiento Suave de Descenso (SDD)



- Load limiting device
- Cross control over
- Hexagonal Section Extensions
- Independent extension cylinders
- Fixed stabilizer cylinders
- Outriggers with hydraulic extension
- Flanged valves
- Oil tank
- Assembly kit
- Design in accordance with EN12999
- Fatigue test classification: B3
- Sprint Generation System (SGS)
- Electronic Black Box (EBB) only Radio
- Soft Descend Drive (SDD)

## EBB Caja negra electrónica



HNOS. TOIMIL GARCÍA, S.L. ha diseñado esta placa madre de control para asegurar un control eficaz y fiable de la grúa en cada condición de trabajo. El operario puede leer en la pantalla toda la información acerca del estado de la grúa, de los accesorios y del mantenimiento rutinario. Todos los componentes están diseñados de acuerdo con los estándares de la industria automovilística y garantizan la más alta fiabilidad.

*HNOS. TOIMIL has designed this control motherboard to assure an effective and reliable control of the crane in every working condition. The operator can read on the display all the information about the state of the crane, the accessories and the routine maintenance. All the components are designed according to automotive industry stds. and assure the highest reliability.*

- + Seguridad
- + Duración
- + Fiabilidad
- + Safety
- + Longer life
- + Certainty

## SDD Movimiento suave de descenso



El sistema SDD está diseñado para reducir las oscilaciones y asegurar un control perfecto de los movimientos.

*The SDD system is designed to reduce the oscillations and assure a perfect control of the motions.*

- + Control
- + Precisión
- + Control
- + Precision

## SGS Sistema extensible regenerativo



El objetivo de este sistema es incrementar la velocidad de las prolongas sin afectar a la seguridad de la grúa.

*Purpose of SGS system is to increase the extensions speed without effecting the crane safety.*

- + Velocidad
- + Speed

Comparativo de velocidad en extensiones  
Extensions speed comparison

| Modelo*  | 2S      | 3S      | 4S      | 5S      | 6S      |
|----------|---------|---------|---------|---------|---------|
| Standard | 20 Sec. | 32 Sec. | 42 Sec. | 51 Sec. | 60 Sec. |
| SGS      | 10 Sec. | 16 Sec. | 22 Sec. | 29 Sec. | 36 Sec. |

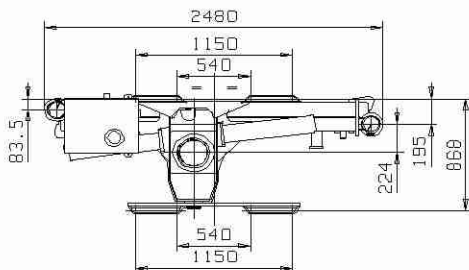
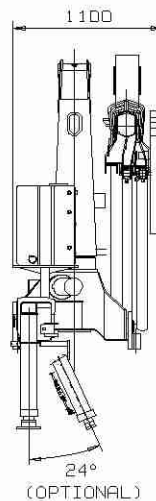
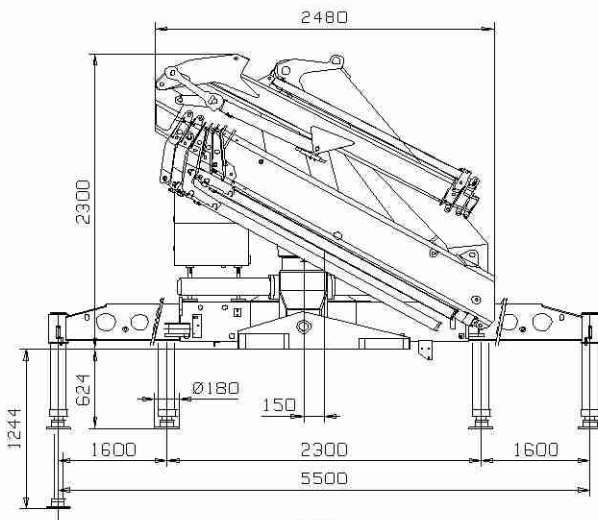

**Hnos. TOIMIL GARCIA, S.L.**  
Equipos Forestales

GRUAS HIDRAULICAS  
Forestales - Industriales - Marinas

Teléfono: + 986 79 40 44 Fax: + 986 79 40 47 Móvil: 609 08 90 06  
36512 PRADO - LALIN - PONTEVEDRA (España)  
E-mail: toimil@toimilgruas.com  
www.toimilgruas.com

**Distribuidor:**  
Distributor:

818.10.0013.01/05-2000